

DE BetteSuno Pedestal
EN BetteSuno Pedestal
FR BetteSuno Pedestal
NL BetteSuno Pedestal

DE Montageanleitung
EN Installation instruction
FR Instructions de montage
NL Montagehandleiding



BETTE

Symbolerklärung



Warnung vor Stromschlag



Warnung vor Wasserschaden



Verweis auf andere Produkte oder Dokumentationen



Ersatzteil



Optional



Korrekte Montage



Falsche Montage



Installationsarbeiten



Bohrmontage



Klebmontage



Dichtheitsprüfung

Sicherheitshinweise

- Eine Gewährleistung in Bezug auf Sicherheit, Funktion und Unversehrtheit des Produkts ist nur gegeben, wenn die Hinweise in dieser Anleitung beachtet werden. Bei Missachtung können Körperverletzungen und Sachschäden auftreten. Der Hersteller haftet nicht für Schäden, die durch Nichtbeachtung der Anweisungen eintreten.
- Gehen Sie unbedingt nach der Anweisung der Montageanleitung vor, um Montagefehler und Schäden am Produkt zu vermeiden.
- Beachten Sie neben den Hinweisen in dieser Anleitung die allgemein gültigen Sicherheits- und Unfallvorschriften.

Hinweise zur Anleitung

- Diese Montageanleitung muss während der gesamten Montage zur Verfügung stehen. Wenn die Montage von verschiedenen Personen (z.B. Installateur, Fliesenleger) durchgeführt wird, muss die Montageanleitung übergeben werden.
- Vorhandene Maßangaben sind in Millimeter (mm) angegeben.
- Die Abbildungen sind nicht maßstabsgerecht.
- Technische Änderungen sind vorbehalten

Montagehinweise

- Die Montage darf nur durch einen Fachmann erfolgen.
- Der Bauuntergrund muss für die Aufnahme des Gewichtes geeignet sein.
- Bei der Montage muss die Dichtigkeit von Garnitur zur Waschsäule geprüft und sichergestellt werden.
- Um Beschädigungen am Produkt zu vermeiden, muss es mit größter Sorgfalt behandelt werden. Ringe und andere Gegenstände die das Produkt beschädigen können, müssen vor der Montage abgelegt werden.
- Schwere und sperrige Elemente müssen mit zwei Personen montiert werden.
- Starke Belastungen (z. B. Draufsetzen) können zu Beschädigungen an der Waschtischkonstruktion führen.
- Wenn in die Wände nicht gebohrt werden kann, kann die Wandhalterung auch vollständig mit der Wand und dem Boden verklebt werden.



Beachten Sie auch separate Dokumentationen (z. B. für Ablaufgarnituren).

Key to symbols



Warning - risk of electric shock



Warning - risk of water damage



Cross reference to other products or documentation



Spare part



Optional



Correct installation



Incorrect installation



Installation work



Drill mounting



Adhesive mounting



Leak test

Safety information

- The safety, function and integrity of the product can only be guaranteed if the information provided here is observed. Failure to do so may result in injury or damage to persons or property. The manufacturer is not liable for any damage resulting from a failure to observe the instructions.
- It is essential that you follow the instructions given in the installation guide in order to prevent installation errors and damage to the product.
- Please observe the general safety and accident prevention regulations in addition to the information provided in these instructions.

About this guide

- This installation guide must be available for the entire duration of the installation process. If the installation is to be carried out by several individuals (e.g. fitter, tiler etc.), then the installation guide must be passed on as appropriate.
- The dimensions are given in mm (millimetres).
- The illustrations are not true to scale.
- Subject to technical changes.











Installation information

- Only to be installed by qualified specialists.
- The underlying structure must be suitable for bearing the weight involved.
- During installation, the tightness of the fittings to the pedestal column must be checked and ensured.
- Handle the product with the greatest care in order to prevent damage. Rings and other items that could damage the product must be removed before installation.
- Large, bulky or heavy items must be installed by two people.
- Heavy loads (e.g. sitting on it) can result in damage to the vanity unit structure.
- If it is not possible to drill into the walls, the wall bracket can also be fully glued to the wall and floor.



Please also observe the separate documentation (e.g. for waste fittings).

Explication des symboles

-  Mise en garde contre les risques d'électrocution
-  Mise en garde contre les risques liés à l'eau
-  Référence aux autres produits ou documentations
-  Pièce détachée
-  En option
-  Montage correct
-  Montage incorrect
-  Travaux d'installation
-  Montage perçage
-  Montage adhésif
-  Recherche de fuite

Consignes de sécurité

- La sécurité, la fonctionnalité et l'intégrité du produit ne sont garanties que si les consignes fournies dans ce manuel sont respectées. Tout manquement à ce point peut entraîner des blessures corporelles et des dommages matériels. Le fabricant décline toute responsabilité pour les dommages survenus du fait du non respect des instructions.
- Procédez strictement comme indiqué dans le manuel de montage pour éviter toute erreur de montage et tout dommage du produit.
- Outre les consignes du présent manuel, tenez compte également des dispositions généralement en vigueur en matière de sécurité et de prévention des accidents.

Instructions

- Les présentes instructions doivent être disponibles durant tout le montage. Lorsque le montage est effectué par différentes personnes (par ex. installateur, carreleur), les instructions de montage doivent être transmises.
- Les cotes sont indiquées en millimètres (mm).
- Les illustrations ne sont pas à l'échelle.
- Sous réserve de modifications techniques.

Instructions de montage

- Le montage ne doit être réalisé que par du personnel qualifié.
- Le support doit pouvoir supporter le poids de l'installation.
- Lors du montage, l'étanchéité entre la garniture et la colonne du lavabo doit être contrôlée et assurée.
- Manipulez le produit avec la plus grande précaution afin d'éviter tout dommage. Les bagues et autres objets susceptibles d'endommager le produit doivent être retirés avant le montage.
- Les éléments lourds et encombrants doivent être montés à l'aide de deux personnes.
- La structure du lavabo risque d'être endommagée en cas de fortes charges (par exemple, si l'on s'assoit dessus).
- S'il n'est pas possible de percer les murs, le support mural peut être entièrement collé au mur et au sol.

-  Tenez compte des différentes documentations (par ex. pour l'évacuation).

Uitleg van de symbolen



Waarschuwing voor elektrische schok



Waarschuwing voor waterschade



Verwijzing naar andere producten of documentatie



Reserveonderdeel



Optioneel



Correcte montage



Verkeerde montage



Installatiewerkzaamheden



Boormontage



Zelfklevende montage



Dichtheidscontrole

Veiligheidsinstructies

- Er is alleen sprake van een garantie met betrekking tot veiligheid, functie en intactheid van het product, als de opmerkingen in deze handleiding in acht worden genomen. Bij niet-naleving kunnen lichamelijk letsel en materiële schade optreden. De producent is niet aansprakelijk voor schade die door het niet in acht nemen van de aanwijzingen optreedt.
- Ga absoluut te werk volgens de aanwijzingen in de montagehandleiding, om montagefouten en schade aan het product te voorkomen.
- Neem naast de instructies in deze handleiding de algemeen geldige veiligheids- en ongevallenvoorschriften in acht.

Opmerkingen bij de handleiding

- Deze montagehandleiding moet tijdens de hele montage ter beschikking staan. Als de montage door verschillende personen (bijv. installateur, tegellegger) wordt uitgevoerd, moet de montagehandleiding overhandigd worden.
- Bestaande maataanduidingen zijn in millimeter (mm) aangegeven.
- De afbeeldingen zijn niet schaalgetrouw.
- Technische wijzigingen zijn voorbehouden.

Montage-instructies

- De montage mag uitsluitend door gekwalificeerd vakpersoneel plaatsvinden.
- De bouwondergrond moet geschikt zijn om het gewicht op te nemen.
- Tijdens de installatie moet de afdichting van de garnituur op de waszuil worden gecontroleerd en afgekit worden aan de wand en vloer.
- Behandel het product uiterst zorgvuldig om beschadigingen te voorkomen. Ringen en andere voorwerpen die het product kunnen beschadigen, moeten vóór de montage worden afgedaan.
- Zware en onhandzame onderdelen moeten met twee personen worden gemonteerd.
- Sterke belastingen (bijv. erop zitten) kunnen leiden tot beschadigingen aan de constructie van de wastafel.
- Als het niet mogelijk is om in de muur te boren, kan de muurbeugel ook volledig aan de muur en vloer worden gelijmd.



Afzonderlijke documentatie (bijv. voor afvoersets) moet in acht worden genomen.

DE Lieferumfang
 EN Scope of delivery
 FR Contenu de la livraison
 NL Leveringsomvang

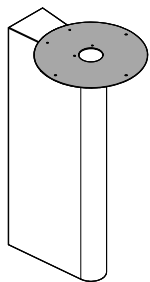

V301
1x

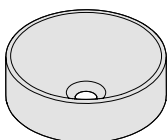

A250
1x

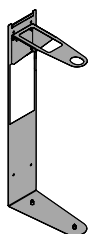

B57-0431
1x

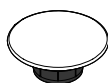

Y101
1x

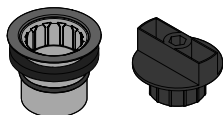

Z0013795
1x

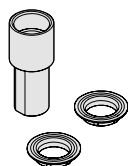

Z0013792
1x

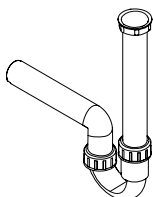

Z0020241
1x

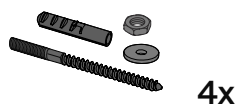

Z0013817
1x

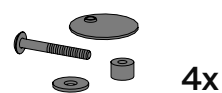

Z0016931
1x

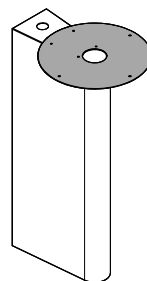

V302
1x

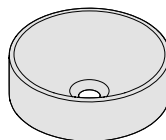

A250
1x



B57-0431
1x



Y101
1x

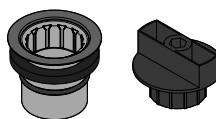

Z0013795
1x

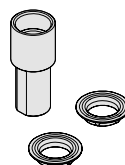

Z0013792
1x

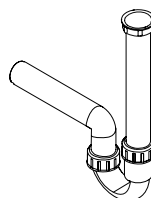

Z0020241
1x

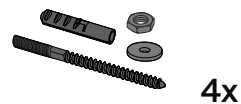

Z0013817
1x

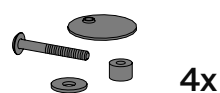

Z0016931
1x

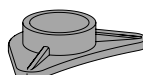

Z0015898
1x

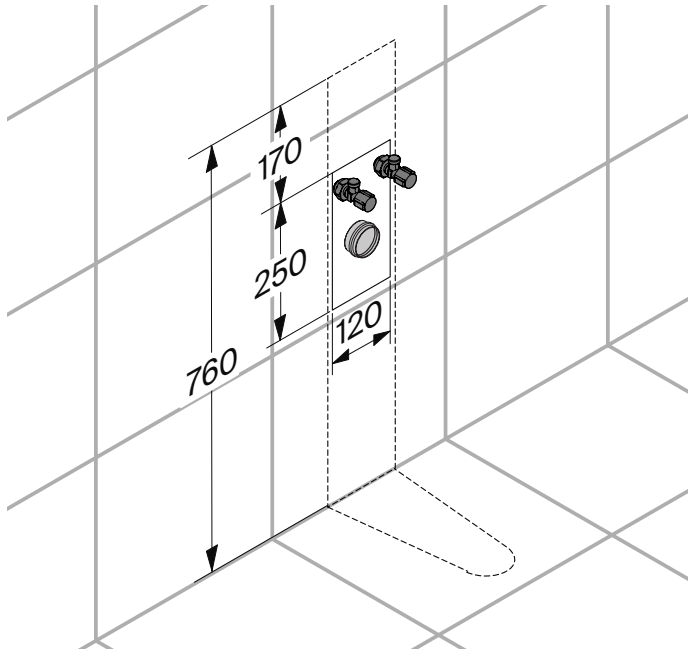

1

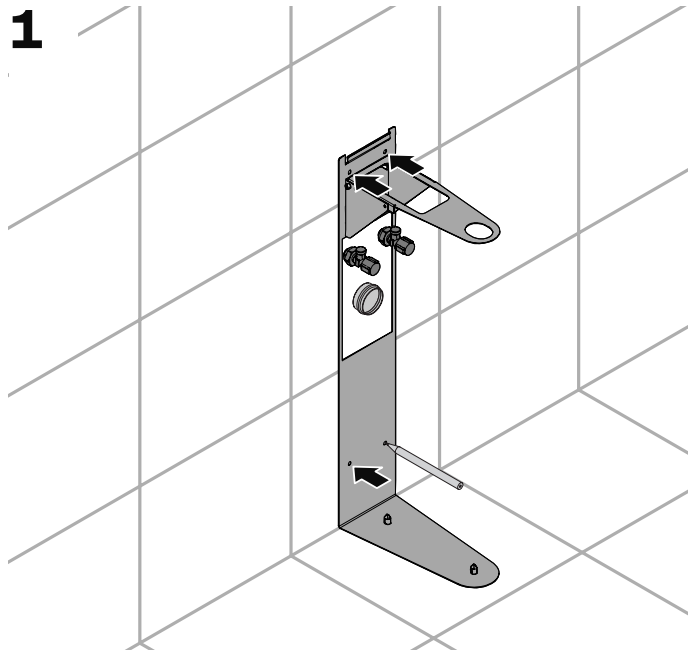

2A

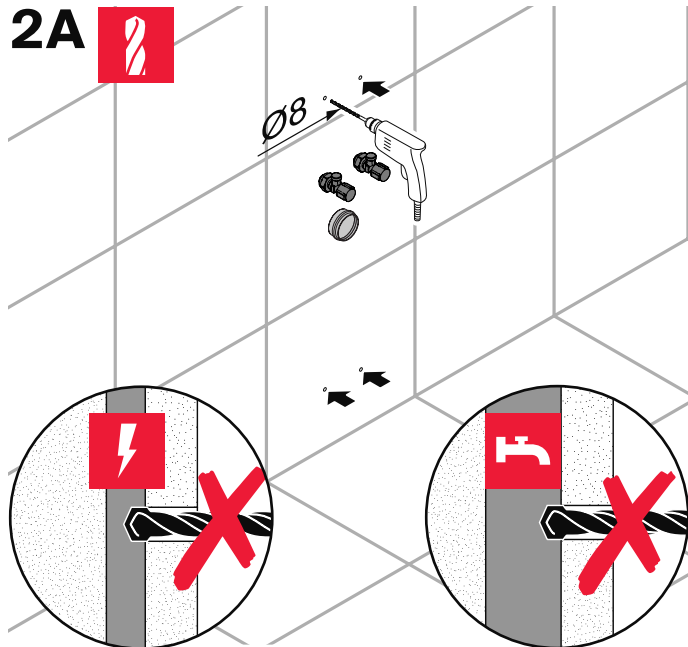

3A

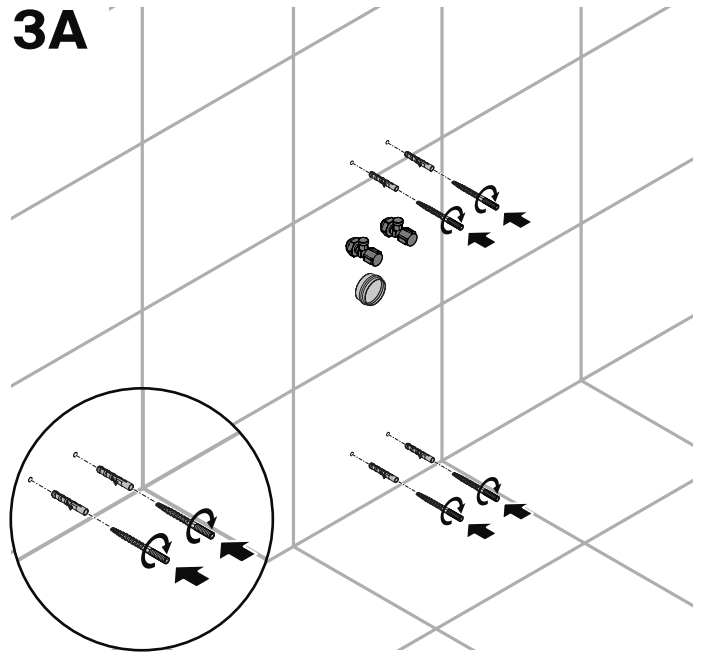

4A

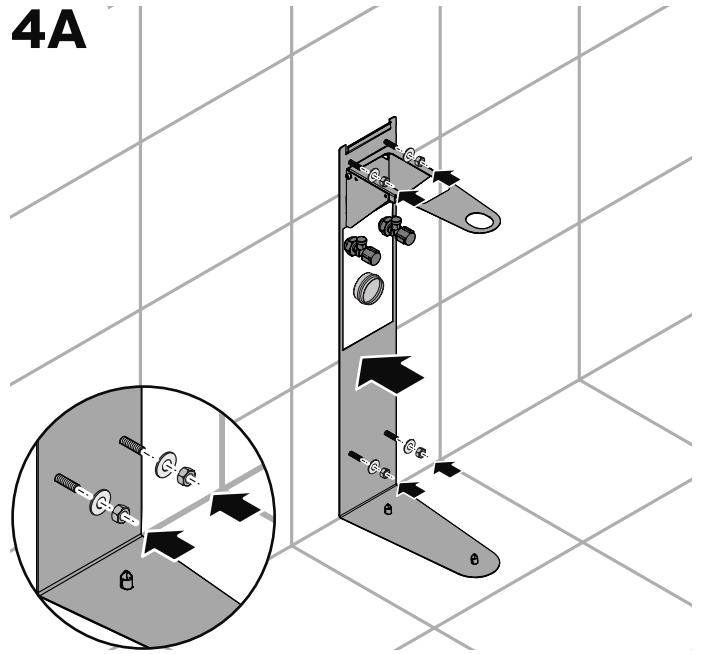

2B

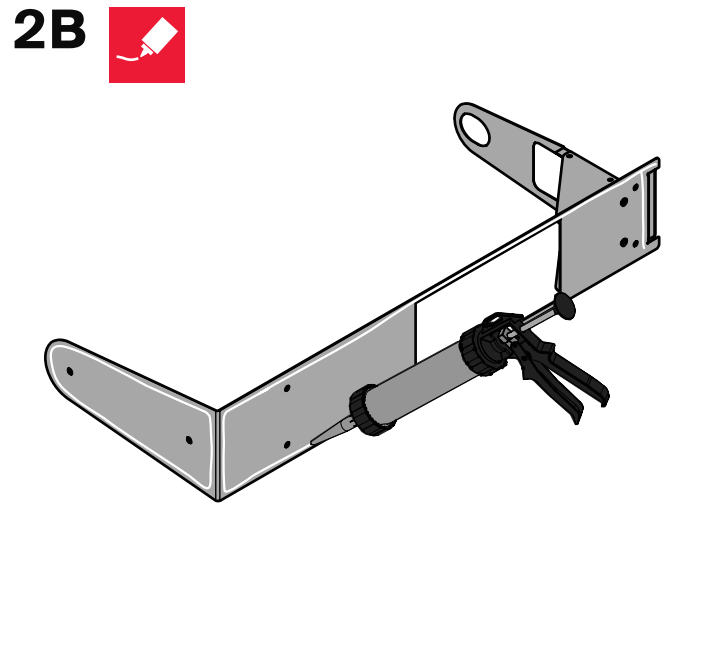

3B

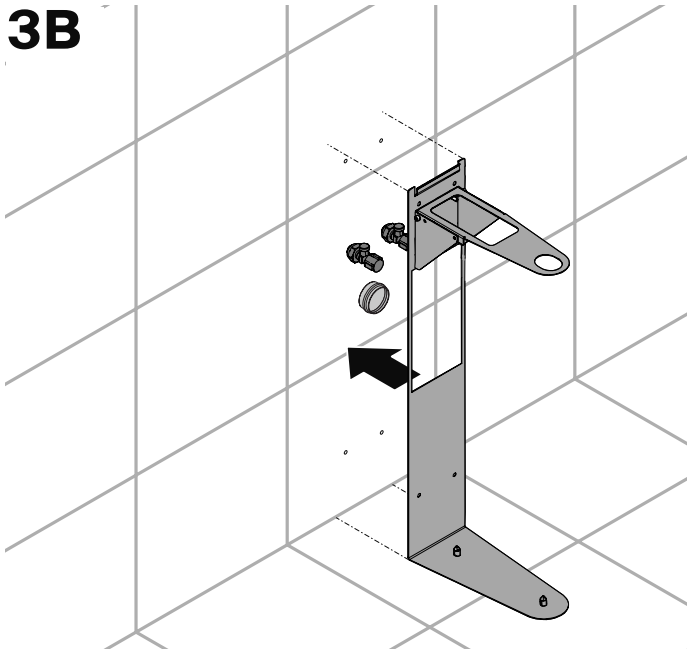

4B

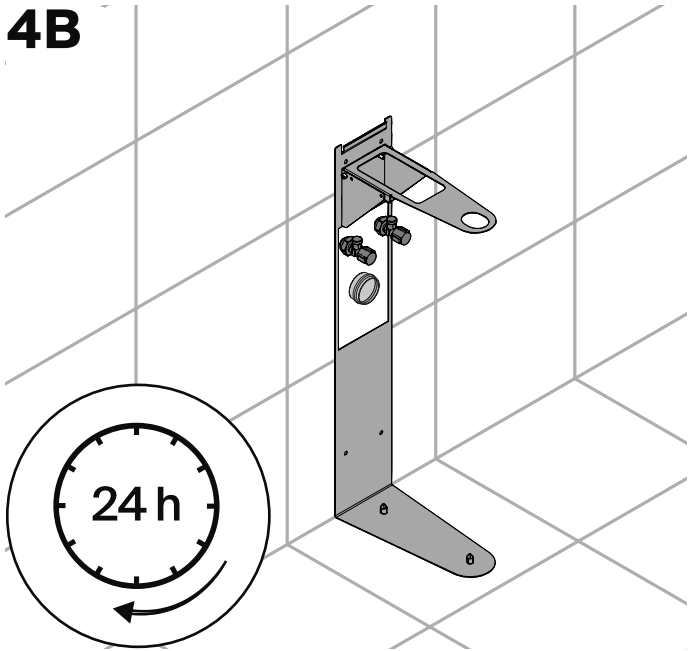

5

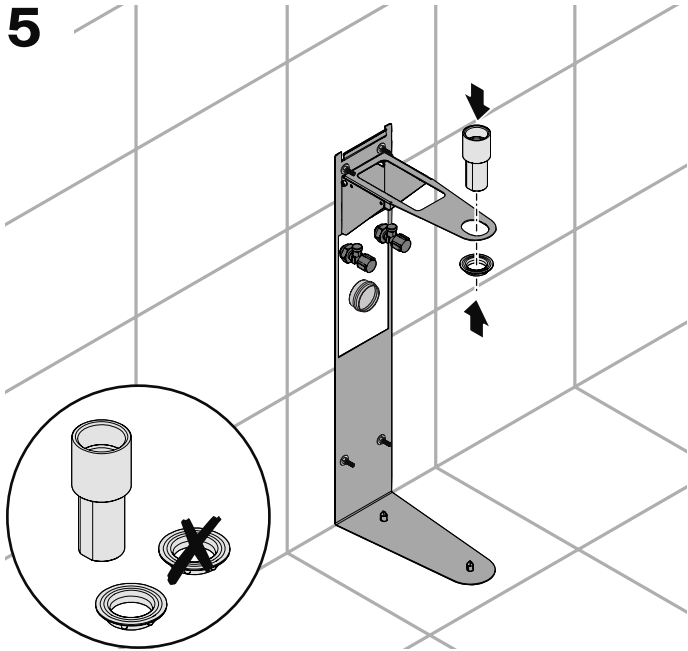

6

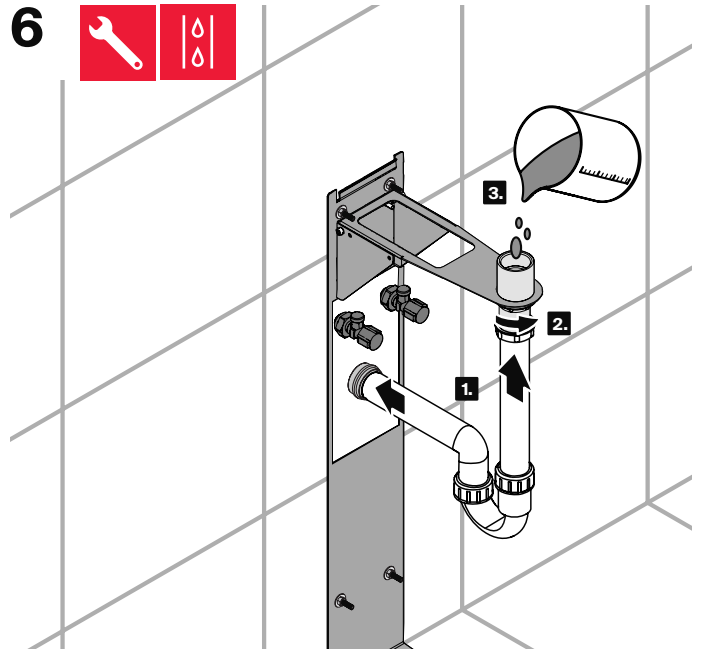

7

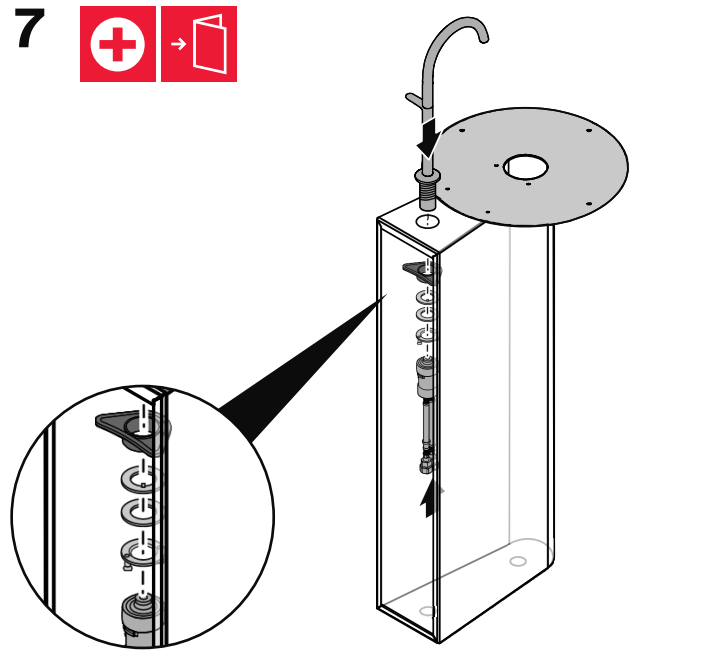

8

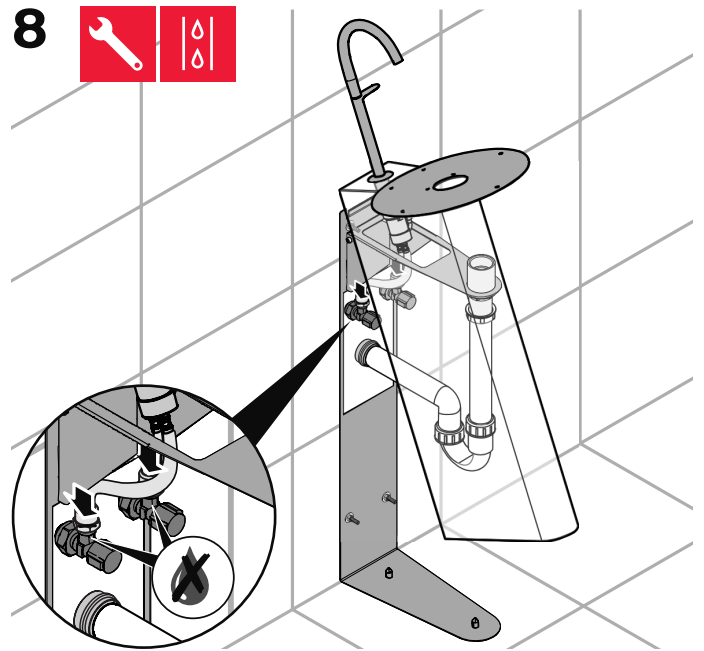

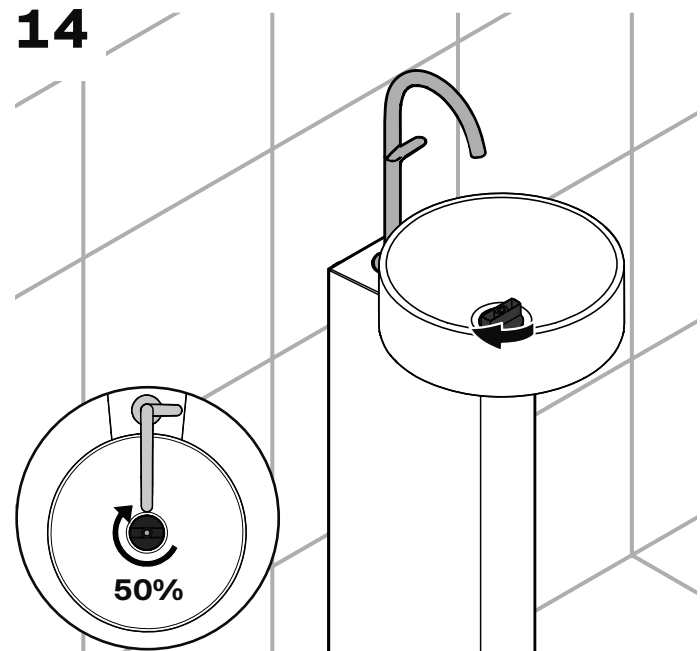
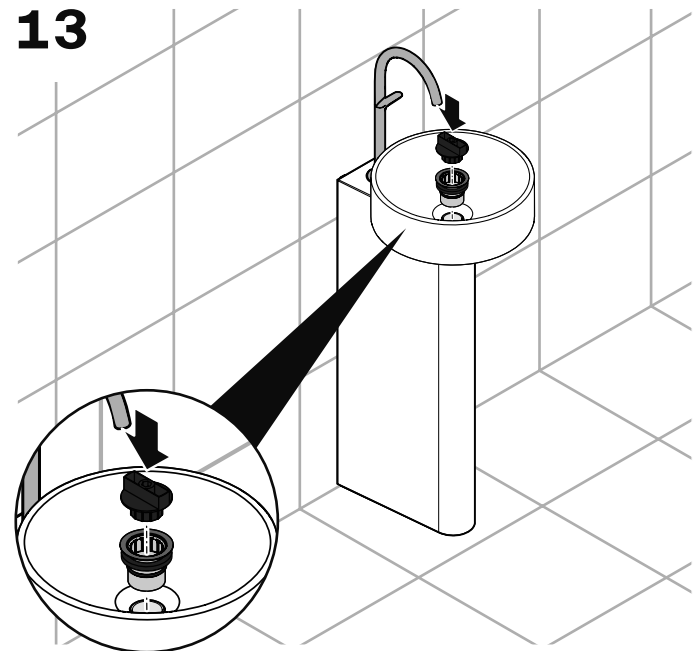
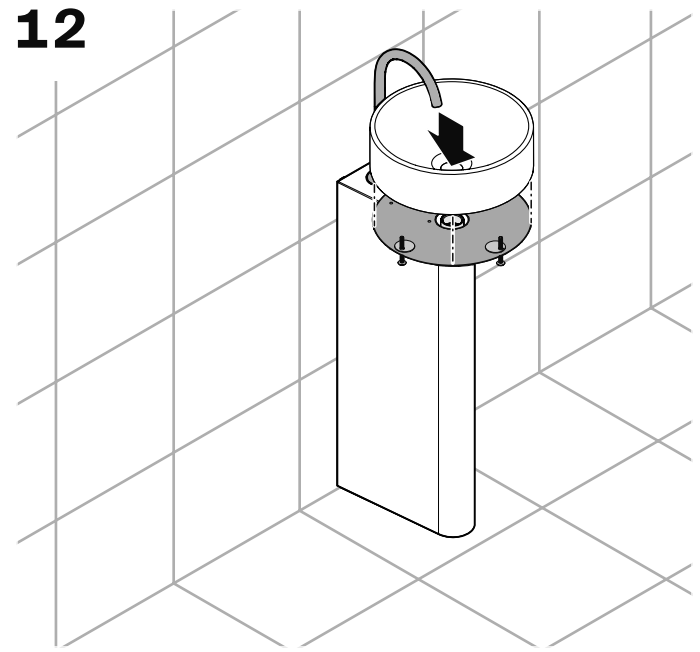
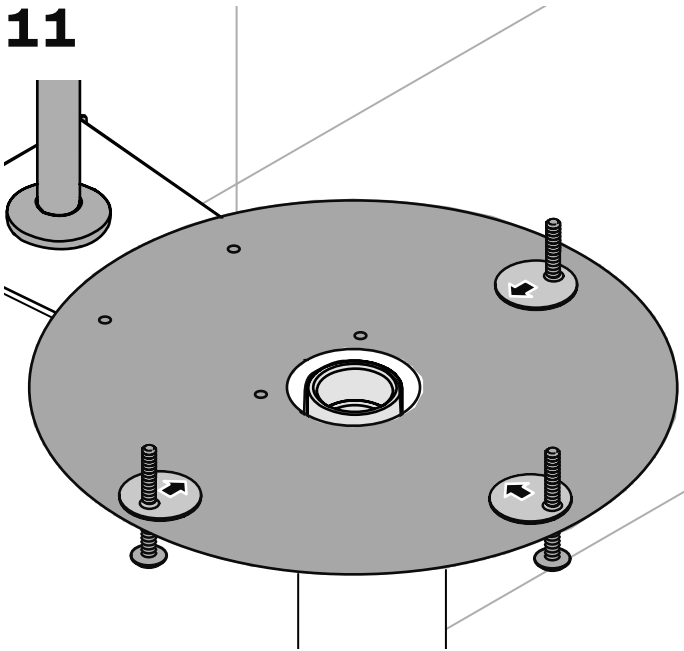
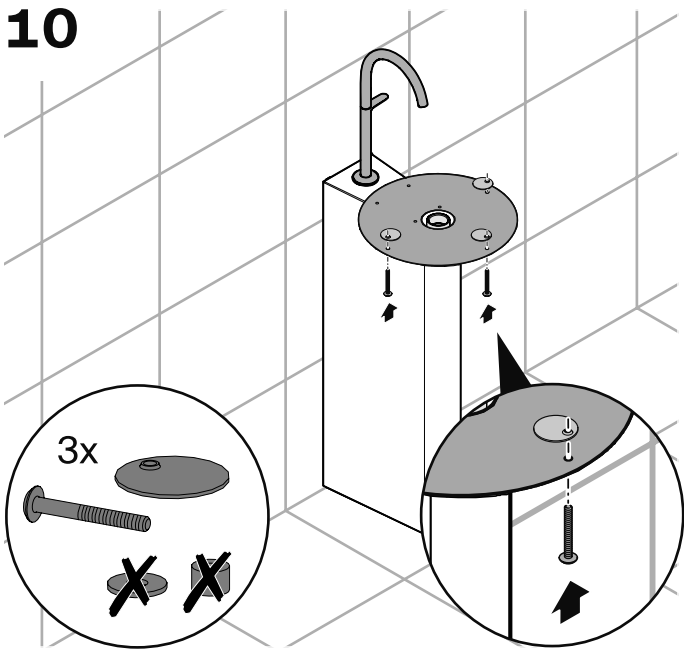
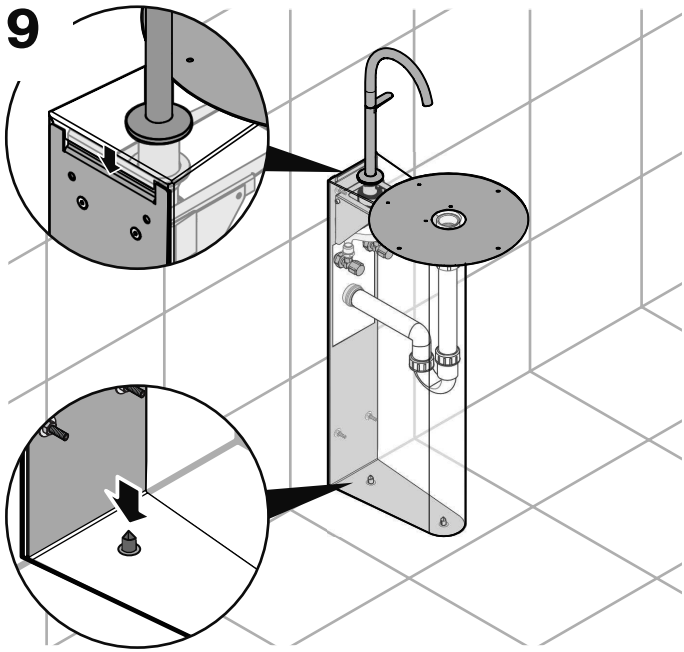

15

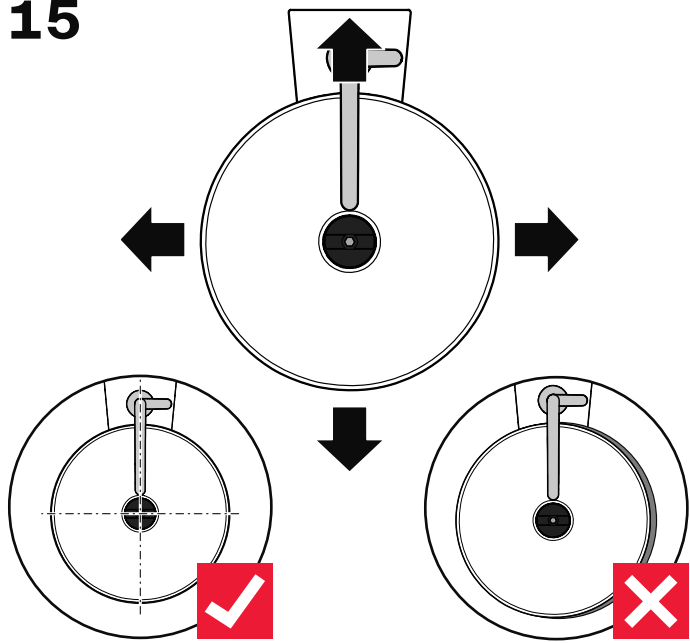

18

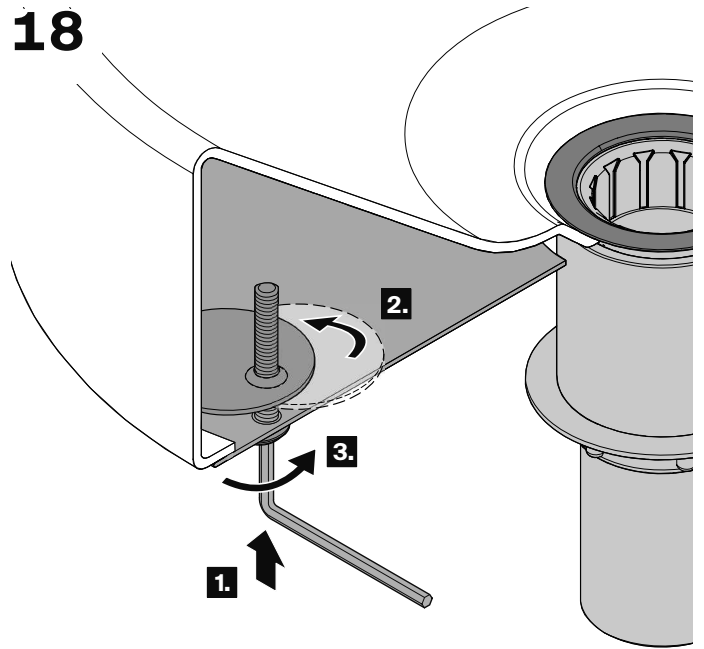

16

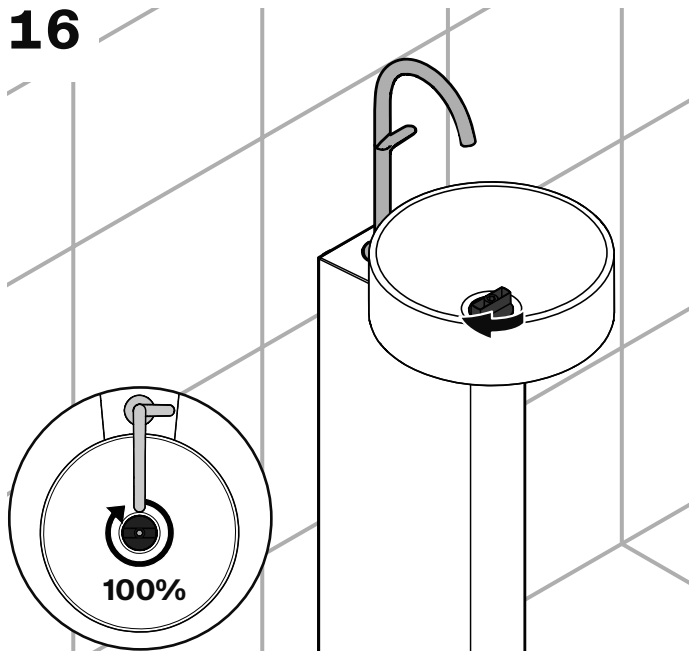

19

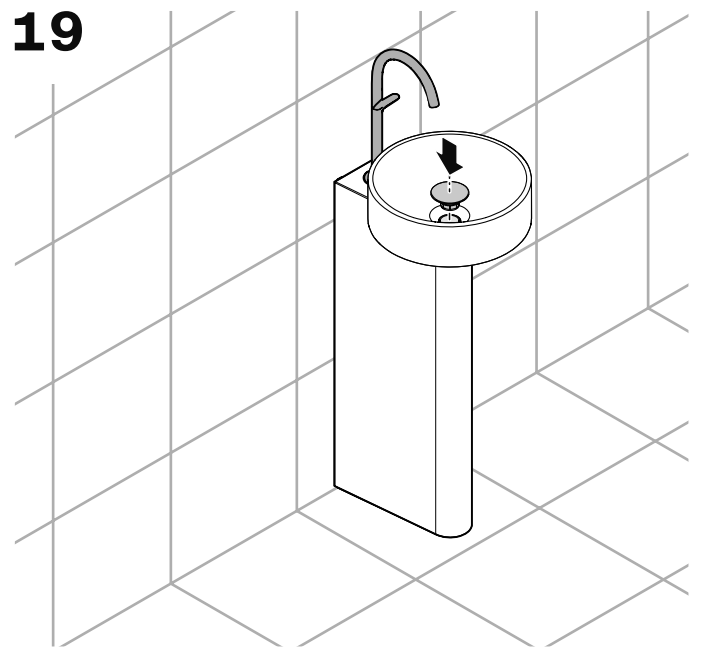

17

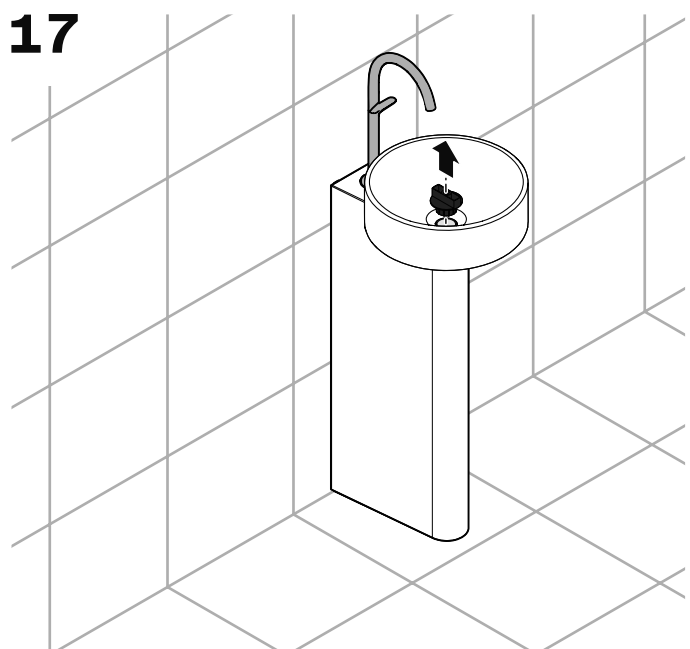

20

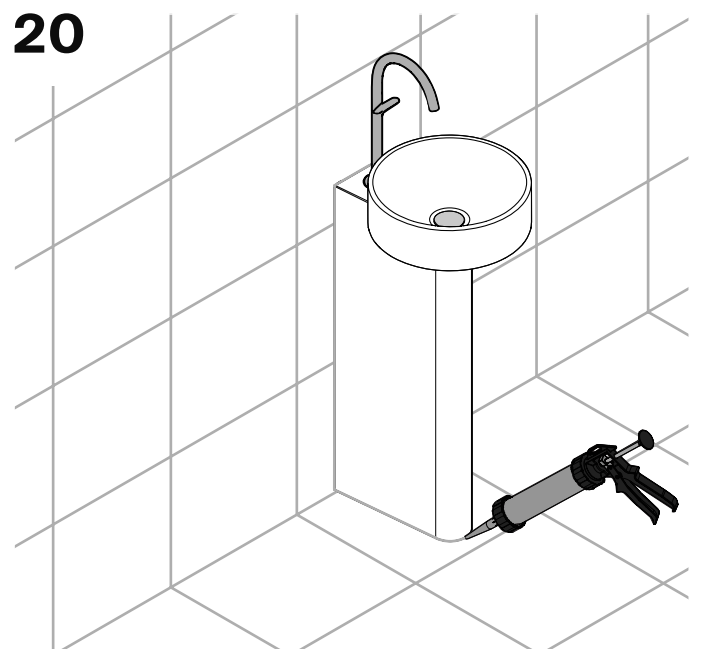

Bette GmbH & Co. KG
Heinrich-Bette-Straße 1
33129 Delbrück
Germany
T +49 5250 511-0
F +49 5250 511-130
info@bette.de

www.my-bette.com

Rev. 1 / 12.2024 / Z0020230